

PRESSURE PIPE REHABILITATION CIPP TECHNOLOGIES

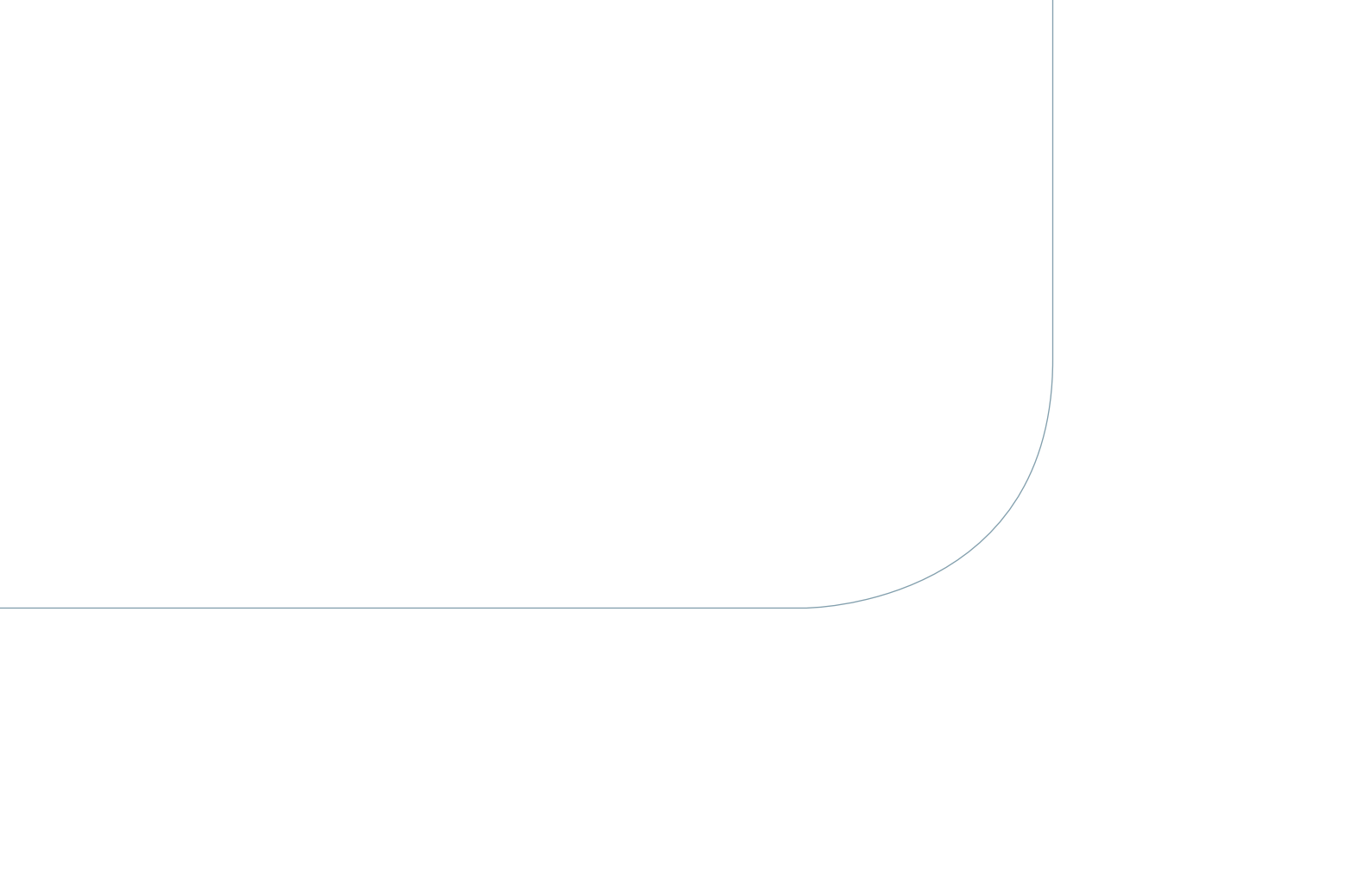

FORMING GLOBAL CONNECTIONS

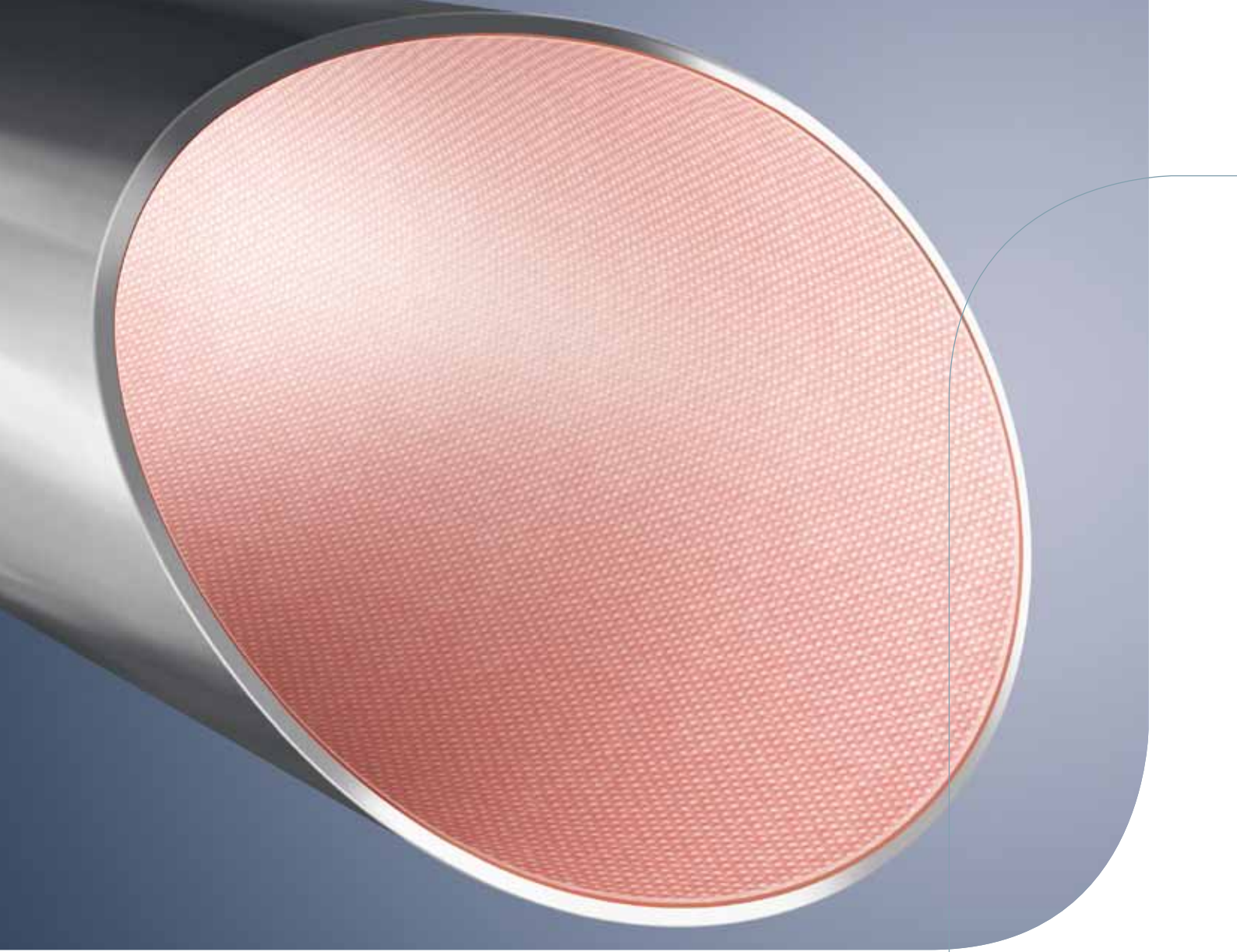



SEKISUI SPR'S REHABILITATION TECHNOLOGIES FOR PRESSURE PIPELINES

SEKISUI SPR is synonymous with the development and implementation of trenchless pipe rehabilitation world-wide. In its activities, SEKISUI SPR uses the two leading key technologies, the spiral wound technology (SPR) and the cured in place pipe technology (CIPP).

SEKISUI SPR's innovative, patented and world renowned cured in place pipe technologies for the rehabilitation of pressure pipes are used the world over for the time and cost efficient means they offer of rehabilitating damaged pipes with minimum impact on the environment.

SEKISUI SPR pressure pipeline rehabilitation products are based on the principle of a liner, impregnated with special resins. It is inverted directly into the old pipe and is to be rehabilitated and thermally cured.

The combination of short installation times and a minimal effect on the environment and infrastructure offers a perfect and cost-effective alternative to conventional pipeline construction. The company's many years of experience in development and manufacturing ensures a long service life for the pipes.

For the CIPP rehabilitation of pressure pipes SEKISUI SPR offers two product lines:

- NORDIPIPE™
- TUBETEX™

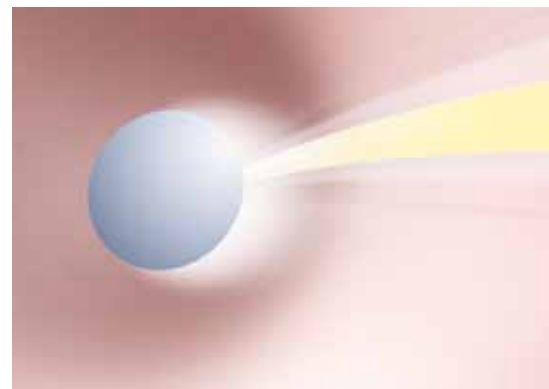

	NORDIPIPE™	TUBETEX™
Medium	Potable water	Gas and potable water
Diameter	150 mm to 1200 mm (6" to 48")	200 mm to 1000 mm (8" to 40")
Material	Felt with glass-fibre reinforcement	Polyester yarn
Coating	PE	PE or Hytrel™

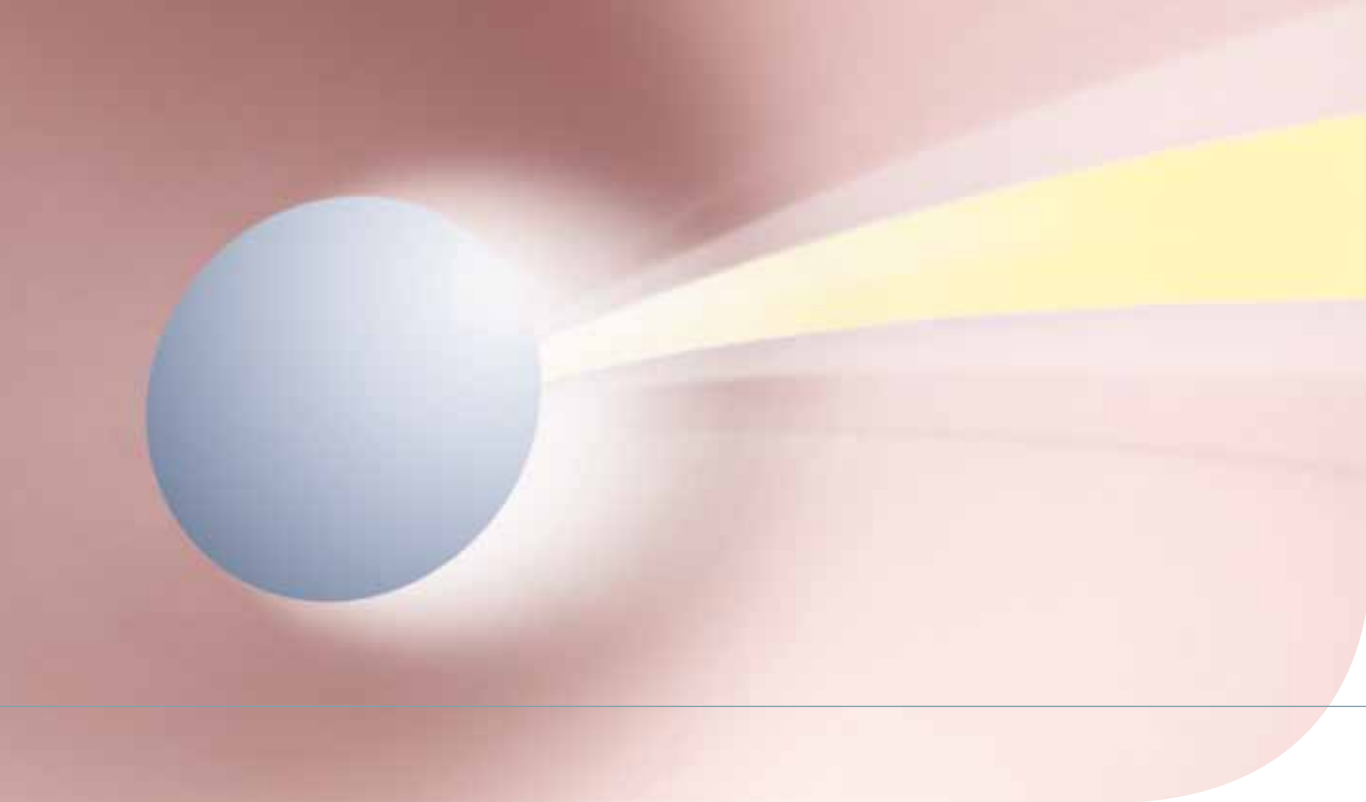

NORDIPIPE™

THE LINER FOR THE REHABILITATION OF WATER PIPES

NORDIPIPE™ from SEKISUI SPR is a high quality, glass-fibre-reinforced pipe liner that has been tailor-made to meet specific requirements. The design gives this pipe liner static, self-supporting properties and allows it to withstand high internal and external loads. This means that it can bear loads statically even without the old pipe, i.e. it can be

called a “stand alone pipe”. This in turn means that rehabilitation can be performed efficiently and quickly (pressure pipes up to PN 10 and PN 16). NORDIPIPE™ is specially tailored for each application. Long lengths are possible.



Heavily encrusted steel pipe



Installation of NORDIPIPE™ liner

NORDIPIPE™ PERFORMANCE DATA

Medium	Potable water
Pressure stage	PN 10 and PN 16
Diameter	150 mm to 1200 mm (6" to 48")
Wall thickness	5.5 to 20.0 mm (0,2" to 0,8")
Coating	PE coating
Applicable resins	Epoxy resin
Installation process	Inversion – pressure drum or water column
Curing process	Steam or hot water

SEKISUI NordiTube Technologies SE – a member of the SEKISUI SPR Europe Group and producer of NORDIPIPE™ – is certified in accordance with ISO 9001 and 14001.

The advantages of NORDIPIPE™ at a glance

- Needled felt liner with glass-fibre
- Liner can withstand internal pressure and is statically self-supporting
- Operating pressure up to PN 10 and PN 16
- Installation of long lengths and through bends is possible
- No bond to the old pipe necessary
- Training of personnel
- Approved for drinking water: AS/NZS 4020, BS6920, NSF 61, GOST, BNQ



Certified to NSF/ANSI 61

STATICALLY SUPPORTING LINER WITH GLASS-FIBRE REINFORCEMENT

SEKISUI SPR can look back on 20 years of experience in the production of pipe liners. With NORDIPIPE™, SEKISUI SPR has developed an innovative pipe liner that – unlike traditional liners – can cover any load case. In order to withstand the loads, NORDIPIPE™ combines the individual components of glass-fibre, needled felt, resin and PE coating, making it the perfect solution for renewal of pressure pipes.

At SEKISUI SPR, quality assurance is a top priority. Quality is also externally monitored by an independent body. This guarantees a minimum service life of 50 years for NORDIPIPE™, a fact which cannot fail to impress.

NORDIPIPE™ is approved for drinking water according to AS/NZS 4020, BS6920, NSF 61, GOST, BNQ.

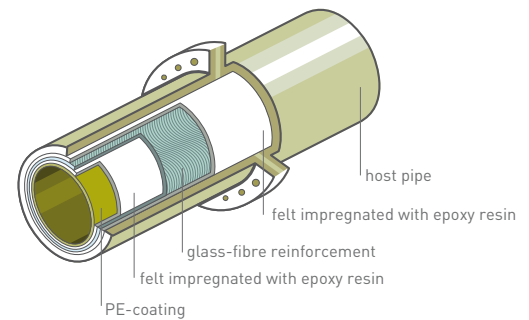

NORDIPIPE™ with a single or two glass-fibre reinforcement layer(s)

COMPARISON - NORDIPIPE™ - HDPE 100 FOR PN 16*

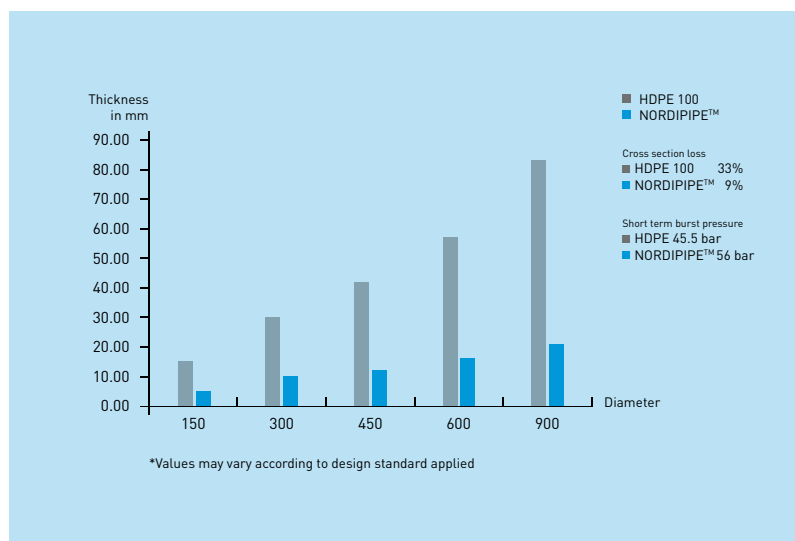



Heavily corroded steel pipe



Cleaning the old pipe with the maximum water pressure up to 2400 bar

TUBETEX™

THE PIPE LINER FOR THE REHABILITATION OF GAS AND POTABLE WATER PIPES

SEKISUI SPR has over 20 years experience in pressure pipe rehabilitation for gas and water pipes with TUBETEX™. TUBETEX™ is the cost-effective solution for pressure pipes with leakages and/or severe sedimentation.

Originally, this type of pipe liner was developed in Japan in order to rehabilitate pipes in seismic areas. As far back as 1986, SEKISUI NordiTube, a member of the SEKISUI SPR Group, brought the system to Europe and since then has continued to develop it. Thanks to the coating that bonds with the round,

woven fabric pipe, as well as the ultra-strong adhesion to the supply pipe, TUBETEX™ is an economical alternative to the costly process of complete renewal for many gas and water supply-related problems.

Two decades of experience and many kilometres of rehabilitated pipes underline the sophistication of TUBETEX™ from SEKISUI SPR. TUBETEX™ is specially tailored for each application. Individual lengths of up to 600 m are possible.

The advantages of TUBETEX™ at a glance

- Licenced product
- Adheres to old pipe but remains extremely flexible
- Approved for drinking water: AS/NZS 4020, DVGW W270, KTW, Ö-Norm, GOST
- Approved for host pipes up to PN 32
- Installations of up to 600 m and through bends are possible
- Support service offered by experts every step of the way
- Training of personnel

SEAMLESS SYSTEMATIC SUCCESS

The TUBETEX™ system is a round, woven, seamless and high-strength pipe liner made out of polyester yarn, which is coated on the inside with PE for water pipes or with Hytrel™ for gas pipes, depending on operational demands. In the process, an epoxy resin (NordiPox TX) creates a connection between the old pipe and the liner. Firmly connected to the old pipe, but elastic enough to counterbalance movements and impacts on the pipes. In comparison with other coatings such

as cement mortar, epoxy or bituminous corrosion protection, the interaction of a high-strength polyester yarn with the epoxy resin and the inner coating produces a longer lasting solution.

In concrete terms, this means rehabilitation with TUBETEX™ prevents interior corrosion, provides long-term protection against incrustations, creates a smooth, leak-proof surface in the pipe and fully enhances the stability of the pipe.

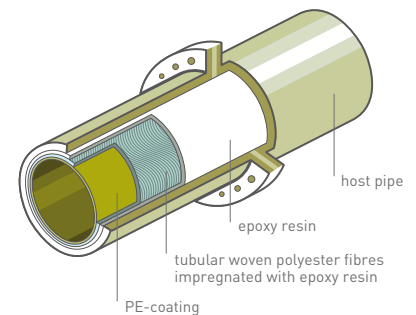

TUBETEX™ under construction



TUBETEX™ burst test



TUBETEX™ continuous production on a tubular loom

TUBETEX™ PERFORMANCE DATA

Medium	Gas and water
Pressure stage	PN 32
Nominal diameter	200 mm to 1000 mm (8" to 40")
Coating	PE or Hytrel™
Installation length	Up to 600 m (1968 feet)
Applicable resins	Epoxy resin (NordiPox TX)
Installation process	Inversion with pressure drum
Curing process	Steam curing

SEKISUI NordiTube Technologies SE – a member of the SEKISUI SPR Europe Group and producer of TUBETEX™ – is certified in accordance with ISO 9001 and 14001.

NORDIPIPE™ CASE STUDY: HIGH-TECH IN OLD MONTREAL

The water pipes in the old part of Montreal, Canada are over 100 years old. In a two-year project, they were successfully rehabilitated with the help of NORDIPIPE™.

Jean-Francois Dubuc, Engineer in the Department of Infrastructure, Transport and Environment of the City of Montreal, was faced with a problem: "The water pipes beneath the historic section of Montreal are old and badly in need of renewal. Most of them were laid over a hundred years ago. They are hardly able to cater for today's demands." The decayed pipes are located deep beneath the busy streets of Montreal's Old Town with its numerous historic buildings, shops and office complexes. SEKISUI SPR proposed a solution for the Montreal Old Town in the form of trenchless pipeline rehabilitation.

Old pipes with a new lining

The contract to recondition the entire pipe network – around 5,000 km in total – was awarded to the construction company Aqua Rehab of Laval, Québec. The first phase to be tackled by the experienced pipe repairers was a 130-metre long water pipe beneath the busy Rue Saint Jacques and Rue Saint Pierre intersection in Montreal. In the evening hours, once the Montreal rush hour had ebbed, the Canadian construction company's team began with the insertion of the NORDIPIPE™ pipe liner inside the old pipes. Further sections of the dilapidated water pipes have been rehabilitated using the proven pipe liner process. By the conclusion of the two-year project, all the city's decayed pipes were as good as new.



On-site impregnation of NORDIPIPE™ (1)



On-site impregnation of NORDIPIPE™ (2)



Rehabilitation in record time

Jean-Francois Dubuc was impressed not only by the minimally disruptive procedure, but also the short time involved for pipeline rehabilitation with NORDIPIPE™. With SEKISUI SPR technology, Aqua Rehab took less than 24 hours to complete pipeline sections of up to 152 metres – a fraction of the time needed for a conventional renewal with excavation. From a financial point of view the project also brings savings

for Dubuc: the elaborate construction involved in “normal” pipeline renewal beneath sensitive city districts such as Old Montreal would have cost the city fathers considerably more. And the approx. 4,000 inhabitants of the Old Town can breathe a sigh of relief. With the trenchless pipeline rehabilitation technology and NORDIPIPE™, they were spared the usual road works, dust, noise and traffic hold-ups.

Everything from a single source.

SEKISUI SPR is synonymous with superior solutions for underground infrastructure worldwide. SEKISUI SPR offers outstanding and environmentally sustainable technologies and services for supply and drainage through its global distribution network. Customers profit from the broad portfolio including trenchless rehabilitation, vacuum sewer systems and pipe inspection. With experts in the rehabilitation, construction and maintenance of underground infrastructure systems worldwide, SEKISUI SPR offers all services from a single source.



THE BEST ALL IN ONE THE BEST FOR YOU - WORLDWIDE

Modern urban life would be utterly impossible without underground infrastructure. However, it is becoming apparent that underground infrastructure systems worldwide are deteriorating substantially as a result of the age of pipe systems and a steady increase in traffic loads. The also rising demands on sustainable and environmentally-friendly urban development pose a major challenge to local authorities. SEKISUI SPR offers the right solutions to meet those challenges. Trenchless technologies permit renewal by rehabilitating the existing infrastructure without protracted construction works and without modification of the cityscape. It is also possible to expand and maintain existing infrastructure systems without excavation. Trenchless technologies guarantee a faster, more cost-effective and environmentally-friendly solution compared to replacement.

SEKISUI SPR employs some of the world's leading technical and operational infrastructure specialists, and is thus in a position to offer a solution for all requirements, from planning through to construction. In delivering those solutions, SEKISUI SPR operates in three divisions: Sales & Support, Trenchless Infrastructure Solutions and Construction. In concrete terms, this provides for a global interchange of experience between individual experts to devise the optimum infrastructure solution for the specific location.

SEKISUI SPR concentrates the international underground infrastructure competencies of the SEKISUI Chemical Corporation (Osaka). It is already represented in over 40 countries on all continents.



 GLOBAL CONNECTION

 PROMINENT TECHNOLOGY

 ENVIRONMENTAL CONTRIBUTION

SALES & SUPPORT

Sales Asia

Sales Europe

Sales America

Sales Australia

TRENCHLESS INFRA-STRUCTURE SOLUTIONS

Trenchless rehabilitation

CIPP

- > NORDIPIPE™
- > TUBETEX™
- > UNILINER™
- > NORDIWALL™
- > PULL-INLINER

SPR

- > SPR™
- > SPR™ PE
- > SPR™ EX
- > SPR™ ST

Vacuum sewer system

- > SIVAC®

Pipe inspection

CONSTRUCTION

Rehabilitation of pipe networks

Pipe construction

Maintenance of drainage systems on waste disposals

MAKE YOUR CONNECTION

SEKISUI SPR SALES EUROPE

Julius-Müller-Straße 12
D-32816 Schieder-Schwalenberg
Germany

T +49 5284 705 0

SEKISUI SPR SALES ASIA

#10-301 The Plaza
7500A Beach Road
Singapore 199591

T +65 629 637 88

SEKISUI SPR SALES AUSTRALIA

587 Grand Junction Road
Gepps Cross, SA 5094
Australia

T +61 8 8260 8000

SEKISUI SPR SALES AMERICA

501 N. El Camino Real , Suite #224
San Clemente, California 92672
USA

T +1 714 27 1030

info@sekisuispr.com
www.sekisuispr.com

SEKISUI



FORMING GLOBAL CONNECTIONS

■ TECHNOLOGY ■ SALES & SUPPORT ■ CONSTRUCTION

